

Computer-Based Instruments

NI 5112 User Manual

Worldwide Technical Support and Product Information

ni.com

National Instruments Corporate Headquarters

11500 North Mopac Expressway Austin, Texas 78759-3504 USA Tel: 512 794 0100

Worldwide Offices

Australia 03 9879 5166, Austria 0662 45 79 90 0, Belgium 02 757 00 20, Brazil 011 284 5011,
Canada (Calgary) 403 274 9391, Canada (Ontario) 905 785 0085, Canada (Québec) 514 694 8521,
China 0755 3904939, Denmark 45 76 26 00, Finland 09 725 725 11, France 01 48 14 24 24,
Germany 089 741 31 30, Greece 30 1 42 96 427, Hong Kong 2645 3186, India 91805275406,
Israel 03 6120092, Italy 02 413091, Japan 03 5472 2970, Korea 02 596 7456, Mexico (D.F.) 5 280 7625,
Mexico (Monterrey) 8 357 7695, Netherlands 0348 433466, New Zealand 09 914 0488, Norway 32 27 73 00,
Poland 0 22 528 94 06, Portugal 351 1 726 9011, Singapore 2265886, Spain 91 640 0085,
Sweden 08 587 895 00, Switzerland 056 200 51 51, Taiwan 02 2528 7227, United Kingdom 01635 523545

For further support information, see the *Technical Support Resources* appendix. To comment on the documentation, send e-mail to techpubs@ni.com

© Copyright 1999, 2000 National Instruments Corporation. All rights reserved.

Important Information

Warranty

The NI 5112 is warranted against defects in materials and workmanship for a period of one year from the date of shipment, as evidenced by receipts or other documentation. National Instruments will, at its option, repair or replace equipment that proves to be defective during the warranty period. This warranty includes parts and labor.

The media on which you receive National Instruments software are warranted not to fail to execute programming instructions, due to defects in materials and workmanship, for a period of 90 days from date of shipment, as evidenced by receipts or other documentation. National Instruments will, at its option, repair or replace software media that do not execute programming instructions if National Instruments receives notice of such defects during the warranty period. National Instruments does not warrant that the operation of the software shall be uninterrupted or error free.

A Return Material Authorization (RMA) number must be obtained from the factory and clearly marked on the outside of the package before any equipment will be accepted for warranty work. National Instruments will pay the shipping costs of returning to the owner parts which are covered by warranty.

National Instruments believes that the information in this document is accurate. The document has been carefully reviewed for technical accuracy. In the event that technical or typographical errors exist, National Instruments reserves the right to make changes to subsequent editions of this document without prior notice to holders of this edition. The reader should consult National Instruments if errors are suspected. In no event shall National Instruments be liable for any damages arising out of or related to this document or the information contained in it.

EXCEPT AS SPECIFIED HEREIN, NATIONAL INSTRUMENTS MAKES NO WARRANTIES, EXPRESS OR IMPLIED, AND SPECIFICALLY DISCLAIMS ANY WARRANTY OF MERCHANTABILITY OR FITNESS FOR A PARTICULAR PURPOSE. CUSTOMER'S RIGHT TO RECOVER DAMAGES CAUSED BY FAULT OR NEGLIGENCE ON THE PART OF NATIONAL INSTRUMENTS SHALL BE LIMITED TO THE AMOUNT THEREFORE PAID BY THE CUSTOMER. NATIONAL INSTRUMENTS WILL NOT BE LIABLE FOR DAMAGES RESULTING FROM LOSS OF DATA, PROFITS, USE OF PRODUCTS, OR INCIDENTAL OR CONSEQUENTIAL DAMAGES, EVEN IF ADVISED OF THE POSSIBILITY THEREOF. This limitation of the liability of National Instruments will apply regardless of the form of action, whether in contract or tort, including negligence. Any action against National Instruments must be brought within one year after the cause of action accrues. National Instruments shall not be liable for any delay in performance due to causes beyond its reasonable control. The warranty provided herein does not cover damages, defects, malfunctions, or service failures caused by owner's failure to follow the National Instruments installation, operation, or maintenance instructions; owner's modification of the product; owner's abuse, misuse, or negligent acts; and power failure or surges, fire, flood, accident, actions of third parties, or other events outside reasonable control.

Copyright

Under the copyright laws, this publication may not be reproduced or transmitted in any form, electronic or mechanical, including photocopying, recording, storing in an information retrieval system, or translating, in whole or in part, without the prior written consent of National Instruments Corporation.

Trademarks

CVI™, LabVIEW™, National Instruments™, ni.com™, PXI™, and VirtualBench™ are trademarks of National Instruments Corporation.

Product and company names mentioned herein are trademarks or trade names of their respective companies.

WARNING REGARDING USE OF NATIONAL INSTRUMENTS PRODUCTS

(1) NATIONAL INSTRUMENTS PRODUCTS ARE NOT DESIGNED WITH COMPONENTS AND TESTING FOR A LEVEL OF RELIABILITY SUITABLE FOR USE IN OR IN CONNECTION WITH SURGICAL IMPLANTS OR AS CRITICAL COMPONENTS IN ANY LIFE SUPPORT SYSTEMS WHOSE FAILURE TO PERFORM CAN REASONABLY BE EXPECTED TO CAUSE SIGNIFICANT INJURY TO A HUMAN.

(2) IN ANY APPLICATION, INCLUDING THE ABOVE, RELIABILITY OF OPERATION OF THE SOFTWARE PRODUCTS CAN BE IMPAIRED BY ADVERSE FACTORS, INCLUDING BUT NOT LIMITED TO FLUCTUATIONS IN ELECTRICAL POWER SUPPLY, COMPUTER HARDWARE MALFUNCTIONS, COMPUTER OPERATING SYSTEM SOFTWARE FITNESS, FITNESS OF COMPILERS AND DEVELOPMENT SOFTWARE USED TO DEVELOP AN APPLICATION, INSTALLATION ERRORS, SOFTWARE AND HARDWARE COMPATIBILITY PROBLEMS, MALFUNCTIONS OR FAILURES OF ELECTRONIC MONITORING OR CONTROL DEVICES, TRANSIENT FAILURES OF ELECTRONIC SYSTEMS (HARDWARE AND/OR SOFTWARE), UNANTICIPATED USES OR MISUSES, OR ERRORS ON THE PART OF THE USER OR APPLICATIONS DESIGNER (ADVERSE FACTORS SUCH AS THESE ARE HEREAFTER COLLECTIVELY TERMED "SYSTEM FAILURES"). ANY APPLICATION WHERE A SYSTEM FAILURE WOULD CREATE A RISK OF HARM TO PROPERTY OR PERSONS (INCLUDING THE RISK OF BODILY INJURY AND DEATH) SHOULD NOT BE RELIANT SOLELY UPON ONE FORM OF ELECTRONIC SYSTEM DUE TO THE RISK OF SYSTEM FAILURE. TO AVOID DAMAGE, INJURY, OR DEATH, THE USER OR APPLICATION DESIGNER MUST TAKE REASONABLY PRUDENT STEPS TO PROTECT AGAINST SYSTEM FAILURES, INCLUDING BUT NOT LIMITED TO BACK-UP OR SHUT DOWN MECHANISMS. BECAUSE EACH END-USER SYSTEM IS CUSTOMIZED AND DIFFERS FROM NATIONAL INSTRUMENTS' TESTING PLATFORMS AND BECAUSE A USER OR APPLICATION DESIGNER MAY USE NATIONAL INSTRUMENTS PRODUCTS IN COMBINATION WITH OTHER PRODUCTS IN A MANNER NOT EVALUATED OR CONTEMPLATED BY NATIONAL INSTRUMENTS, THE USER OR APPLICATION DESIGNER IS ULTIMATELY RESPONSIBLE FOR VERIFYING AND VALIDATING THE SUITABILITY OF NATIONAL INSTRUMENTS PRODUCTS WHENEVER NATIONAL INSTRUMENTS PRODUCTS ARE INCORPORATED IN A SYSTEM OR APPLICATION, INCLUDING, WITHOUT LIMITATION, THE APPROPRIATE DESIGN, PROCESS AND SAFETY LEVEL OF SUCH SYSTEM OR APPLICATION.

Compliance

FCC/Canada Radio Frequency Interference Compliance*

Determining FCC Class

The Federal Communications Commission (FCC) has rules to protect wireless communications from interference. The FCC places digital electronics into two classes. These classes are known as Class A (for use in industrial-commercial locations only) or Class B (for use in residential or commercial locations). Depending on where it is operated, this product could be subject to restrictions in the FCC rules. (In Canada, the Department of Communications (DOC), of Industry Canada, regulates wireless interference in much the same way.)

Digital electronics emit weak signals during normal operation that can affect radio, television, or other wireless products. By examining the product you purchased, you can determine the FCC Class and therefore which of the two FCC/DOC Warnings apply in the following sections. (Some products may not be labeled at all for FCC; if so, the reader should then assume these are Class A devices.)

FCC Class A products only display a simple warning statement of one paragraph in length regarding interference and undesired operation. Most of our products are FCC Class A. The FCC rules have restrictions regarding the locations where FCC Class A products can be operated.

FCC Class B products display either a FCC ID code, starting with the letters **EXN**, or the FCC Class B compliance mark that appears as shown here on the right.

Consult the FCC web site <http://www.fcc.gov> for more information.

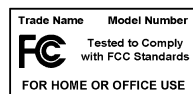

FCC/DOC Warnings

This equipment generates and uses radio frequency energy and, if not installed and used in strict accordance with the instructions in this manual and the CE Mark Declaration of Conformity**, may cause interference to radio and television reception. Classification requirements are the same for the Federal Communications Commission (FCC) and the Canadian Department of Communications (DOC).

Changes or modifications not expressly approved by National Instruments could void the user's authority to operate the equipment under the FCC Rules.

Class A

Federal Communications Commission

This equipment has been tested and found to comply with the limits for a Class A digital device, pursuant to part 15 of the FCC Rules. These limits are designed to provide reasonable protection against harmful interference when the equipment is operated in a commercial environment. This equipment generates, uses, and can radiate radio frequency energy and, if not installed and used in accordance with the instruction manual, may cause harmful interference to radio communications. Operation of this equipment in a residential area is likely to cause harmful interference in which case the user will be required to correct the interference at his own expense.

Canadian Department of Communications

This Class A digital apparatus meets all requirements of the Canadian Interference-Causing Equipment Regulations.

Cet appareil numérique de la classe A respecte toutes les exigences du Règlement sur le matériel brouilleur du Canada.

Class B

Federal Communications Commission

This equipment has been tested and found to comply with the limits for a Class B digital device, pursuant to part 15 of the FCC Rules. These limits are designed to provide reasonable protection against harmful interference in a residential installation. This equipment generates, uses and can radiate radio frequency energy and, if not installed and used in accordance with the instructions, may cause harmful interference to radio communications. However, there is no guarantee that interference will not occur in a particular installation. If this equipment does cause harmful interference to radio or television reception, which can be determined by turning the equipment off and on, the user is encouraged to try to correct the interference by one or more of the following measures:

- Reorient or relocate the receiving antenna.
- Increase the separation between the equipment and receiver.

- Connect the equipment into an outlet on a circuit different from that to which the receiver is connected.
- Consult the dealer or an experienced radio/TV technician for help.

Canadian Department of Communications

This Class B digital apparatus meets all requirements of the Canadian Interference-Causing Equipment Regulations.

Cet appareil numérique de la classe B respecte toutes les exigences du Règlement sur le matériel brouilleur du Canada.

European Union - Compliance to EEC Directives

Readers in the EU/EEC/EEA must refer to the Manufacturer's Declaration of Conformity (DoC) for information** pertaining to the CE Mark compliance scheme. The Manufacturer includes a DoC for most every hardware product except for those bought for OEMs, if also available from an original manufacturer that also markets in the EU, or where compliance is not required as for electrically benign apparatus or cables.

* Certain exemptions may apply in the USA, see FCC Rules §15.103 **Exempted devices**, and §15.105(c). Also available in sections of CFR 47.

** The CE Mark Declaration of Conformity will contain important supplementary information and instructions for the user or installer.

Conventions

The following conventions are used in this manual:

<>

Angle brackets that contain numbers separated by an ellipsis represent a range of values associated with a bit or signal name—for example, DBIO<3..0>.

»

The » symbol leads you through nested menu items and dialog box options to a final action. The sequence **File»Page Setup»Options** directs you to pull down the **File** menu, select the **Page Setup** item, and select **Options** from the last dialog box.



This icon denotes a note, which alerts you to important information.



This icon denotes a warning, which advises you of precautions to take to avoid being electrically shocked.

bold

Bold text denotes items that you must select or click on in the software, such as menu items and dialog box options. Bold text also denotes parameter names.

italic

Italic text denotes variables, emphasis, a cross reference, or an introduction to a key concept. This font also denotes text that is a placeholder for a word or value that you must supply.

monospace

This font is used for the proper names of disk drives, paths, directories, programs, subprograms, subroutines, device names, filenames and extensions, and code excerpts.

Contents

Chapter 1

Taking Measurements with the NI 5112

Installing the Software and Hardware	1-1
Connecting Signals	1-1
Acquiring Data with Your NI 5112	1-3
Programmatically Controlling Your NI 5112.....	1-3
Interactively Controlling Your NI 5112 with VirtualBench-Scope	1-3
Acquiring Data.....	1-4
Soft Front Panel Features.....	1-6
Safety Information	1-7

Chapter 2

Hardware Overview

Measurement Fundamentals	2-2
Input Ranges.....	2-2
Input Impedance	2-2
AC Coupling.....	2-3
DC Offset.....	2-4
20 MHz Bandwidth Limit	2-4
External Trigger.....	2-5
Acquisition System	2-5
Acquisition Modes.....	2-5
Calibration	2-6
Internally Calibrating the NI 5112	2-6
When Internal Calibration Is Needed.....	2-7
What Internal Calibration Does	2-7
External Calibration.....	2-7
Triggering and Arming	2-8
Analog Trigger Circuit	2-8
High-Hysteresis Analog Triggering Mode	2-9
Low-Hysteresis Analog Triggering Mode	2-9
Rising-Edge Analog Trigger.....	2-9
Falling-Edge Analog Trigger.....	2-10
Trigger Hold-Off	2-10
Memory.....	2-11

Multiple Record Acquisitions.....	2-11
Synchronizing Multiple Devices	2-12
Synchronizing Multiple PXI Devices	2-12
Synchronizing Multiple PCI Devices	2-13
PFI Lines and Synchronization	2-13
PFI Lines as Inputs	2-14
PFI Lines as Outputs.....	2-14

Appendix A Specifications

Appendix B Digitizer Basics

Appendix C Technical Support Resources

Glossary

Index

Taking Measurements with the NI 5112

Thank you for buying a National Instruments 5112 digital oscilloscope. This chapter provides information on installing, connecting signals to, and acquiring data from the NI 5112.

Installing the Software and Hardware

There are two main steps involved in installation:

1. Install the NI-SCOPE driver software. You use this driver to write programs to control your NI 5112 in different application development environments (ADEs). NI-SCOPE also allows you to interactively control your NI 5112 with VirtualBench-Scope.
2. Install your NI 5112. For step-by-step instructions for installing NI-SCOPE and the NI 5112, see the *Where to Start with Your National Instruments Oscilloscope/Digitizer*.

Connecting Signals

Figure 1-1 shows the front panel for the NI 5112, which contains five connectors—three BNC connectors, an SMB connector, and a 9-pin miniature circular DIN connector.

Two of the BNC connectors, CH0 and CH1, are for attaching the analog input signals you wish to measure. The third BNC connector, TRIG, is for the analog trigger channel. The SMB connector, PFI1, is for external digital triggers and for generating a probe compensation signal. The DIN connector, AUX, gives you access to an additional external digital trigger line, PFI2.

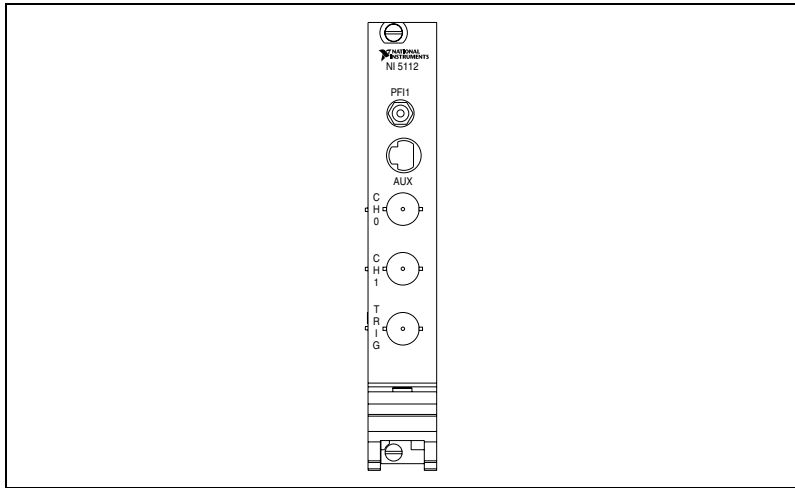

Figure 1-1. NI 5112 Connectors

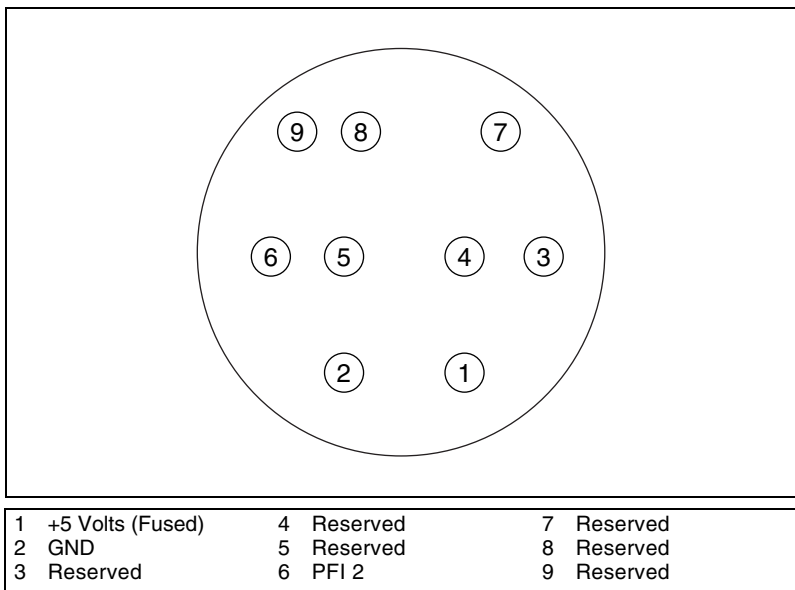

Figure 1-2. 9-Pin Mini Circular DIN Connector

Acquiring Data with Your NI 5112

You can acquire data either programmatically—by writing an application for your NI 5112—or interactively with the VirtualBench-Scope soft front panel.

Programmatically Controlling Your NI 5112

To help you get started programming your NI 5112, NI-SCOPE comes with examples that you can use or modify.

You can find examples for these different ADEs:

- LabVIEW—Go to Program Files\National Instruments\LabVIEW\Examples\Instr\niScopeExamples.llb.
- CVI, C, and Visual Basic with Windows 98/95—Go to vxipnp\win95\Niscope\Examples.
- CVI, C, and Visual Basic with Windows 2000/NT—Go to vxipnp\winnt\Niscope\Examples.

Other resources include the *NI-SCOPE Instrument Driver Quick Reference Guide*. It contains abbreviated information on the most commonly used functions and LabVIEW VIs. For more detailed function reference help, see the *NI-SCOPE Function Reference Help* file, located at **Start»Programs»National Instruments SCOPE**. For more detailed VI help, use LabVIEW context-sensitive help (**Help»Show Context Help**).

Interactively Controlling Your NI 5112 with VirtualBench-Scope

Use the VirtualBench-Scope soft front panel to interactively control your NI 5112 as you would a desktop oscilloscope.

The following sections explain how to make connections to your NI 5112 and take simple measurements using the VirtualBench-Scope soft front panel, as shown in Figure 1-3 later in this chapter. To launch the soft front panel, select **Start»Programs»National Instruments SCOPE»VirtualBench-Scope**.

Acquiring Data

When you launch VirtualBench-Scope, it operates in continuous run mode. To start acquiring signals with VirtualBench-Scope, complete the following steps:

1. Connect a signal to channel 0 and/or channel 1 of your NI 5112.
2. Configure VirtualBench-Scope.
 - a. From the **Edit** menu on the front panel, select **General Settings**.
 - b. **Select NI 5112 from the** instrument list as shown in Figure 1-3. If NI 5112 is not in the device list, make sure you have properly configured the device using Measurement & Automation Explorer (MAX). For more information on how to configure your NI 5112 in MAX, refer to the *Where to Start with Your Oscilloscope/Digitizer* documentation that shipped with your NI 5112.
 - c. Click **OK** to use these settings.

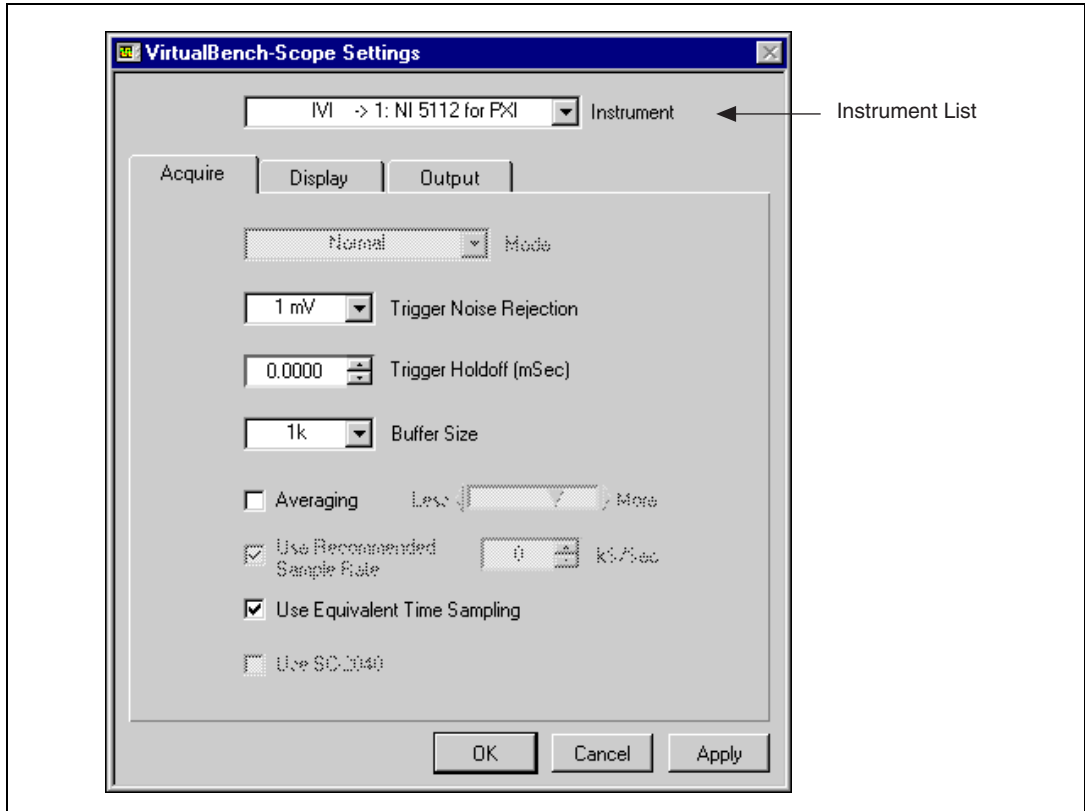

Figure 1-3. Acquire Tab of VirtualBench-Scope Settings Dialog Box



Note When you launch VirtualBench-Scope, it automatically uses the settings of your previous VirtualBench-Scope session.

3. Enable the **Ch 0** and/or **Ch 1** button in the channel selector area. Disable all other channels. Disabled channels have a gray frame around them.
4. Click **Auto Setup** on the main control bar.
5. Click **Run** to start the acquisition.



Note Refer to the *VirtualBench-Scope Online Help* for additional help configuring VirtualBench-Scope for your specific application.

Soft Front Panel Features

The following figure shows the VirtualBench-Scope soft front panel.

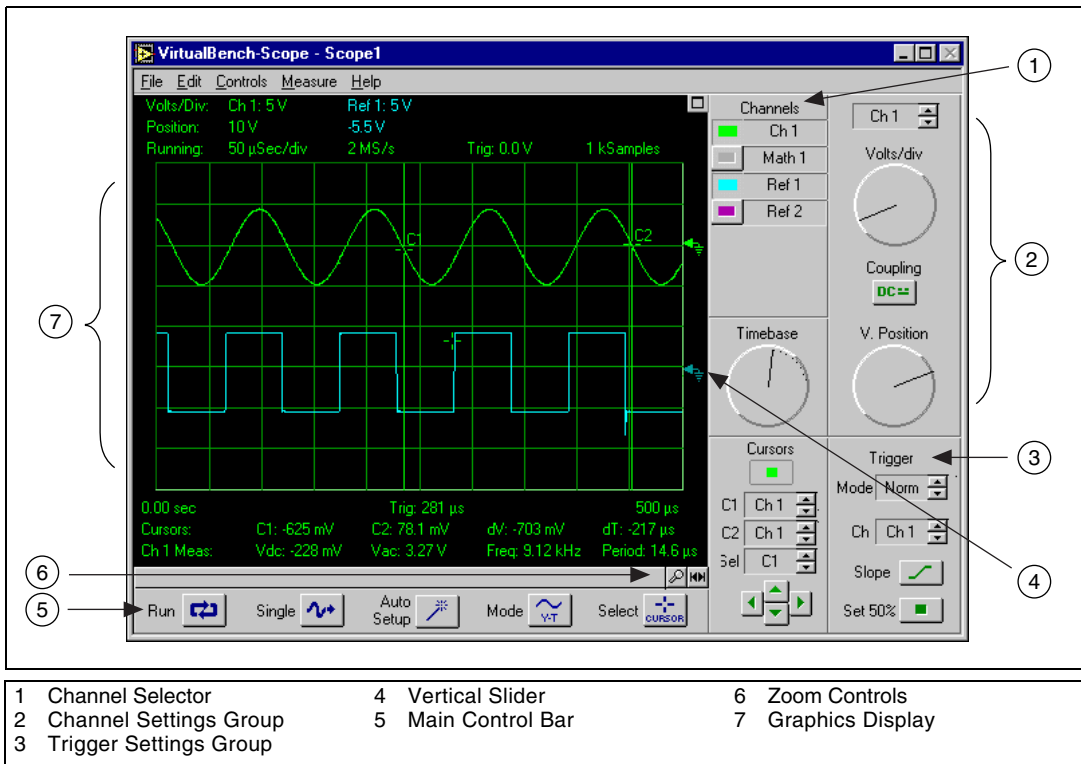

Figure 1-4. VirtualBench-Scope Soft Front Panel

The VirtualBench-Scope soft front panel has the following features:

- **Channel selector** picks channels or math functions that display waveforms.
- Channel settings group:
 - **Channel settings selector** selects the channel whose settings will be modified.
 - **Coupling** toggles between DC and AC coupling.
 - **Volts/div** adjusts the vertical resolution of the channel you select.
 - **V. Position** controls the displayed voltage offset.

- **Trigger settings group** controls the conditions required for signal acquisition. For example, you can command VirtualBench-Scope to wait for a digital trigger or command it to acquire data without triggering (in free-run mode).
- **Vertical Slider** adjusts the voltage offset for each channel. Use this slider to adjust multiple waveforms.
- Main control bar buttons:
 - **Run** acquires data continuously. Deselecting this button places the VirtualBench-Scope in idle mode.
 - **Single** instructs VirtualBench-Scope to perform a single-sweep acquisition.
 - **Auto Setup** configures the scope for the best timebase, volts per division, and trigger setting for each channel currently selected with the channel selector.
 - **Mode** sets the mode of the scope to either volts versus time or X versus Y mode.
 - **Select CURSOR** activates two cursors on the waveform display.
- The zoom controls adjust the view of your display data. Click the magnifying glass icon to zoom in on the displayed data. Click the arrows to the right of the magnifying glass to zoom out to full scale.
- **Timebase** controls the length of time period that is displayed. Turn the knob clockwise to reduce the time period. Each horizontal division represents one time period.



Note Refer to the *VirtualBench-Scope Online Help* for additional help on the front panel items.

Safety Information

The following paragraphs contain important safety information concerning hazardous voltages and hazardous operating conditions. Please adhere to these safety instructions while configuring or connecting signals to the NI 5112.



Warnings *Shock Hazard*—Only qualified personnel aware of the dangers involved should install this unit. Disconnect all power before installing or removing the device. If signal wires are connected to the device, dangerous voltages may exist even when the equipment is turned off. Before you remove the device, disconnect the AC power line or any high-voltage sources, $\geq 30 V_{\text{rms}}$ and $42.4 V_{\text{peak}}$, or 60 VDC, that may be connected to the device.

Do not operate the device in an explosive atmosphere or where there may be flammable gases or fumes.

To ensure adequate grounding, the device must be properly installed in the chassis. National Instruments is *not* liable for any damages or injuries resulting from inadequate safety earth ground connections.

You must insulate all of your signal connections to the highest voltage with which the NI 5112 may come in contact.

Equipment described in this document must be used in an Installation Category II or lower environment per IEC-61010-1 and UL-3111-1.

Do not operate damaged equipment. The safety-protection features built into this device can be impaired if the device becomes damaged in any way. If it is damaged, turn the device off, and do not use it until service-trained personnel can check its safety. If necessary, return the device to National Instruments for service and repair to ensure that its safety is not compromised.

Clean the device and accessories by brushing off light dust with a soft non-metallic brush. Remove other contaminants with a stiff non-metallic brush. The unit must be completely dry and free from contaminants before returning it to service.

The device must be used in a UL-listed chassis.

Do not substitute parts or modify equipment. Because of the danger posed by introducing additional hazards, do not install unauthorized parts or modify the device. Return the device to National Instruments for service and repair to ensure that its safety features are not compromised.

Connections, including power signals to ground and vice versa, that exceed any of the maximum signal ratings on the NI 5112 can damage any or all of the devices in the same chassis. National Instruments is *not liable for any damages or injuries* resulting from incorrect signal connections.

Use only National Instruments oscilloscope probes or probes bearing the CE mark.

Hardware Overview

This chapter includes an overview of the NI 5112, explains the operation of each functional unit making up your NI 5112, and describes the signal connections. Figure 2-1 shows a block diagram of the NI 5112.

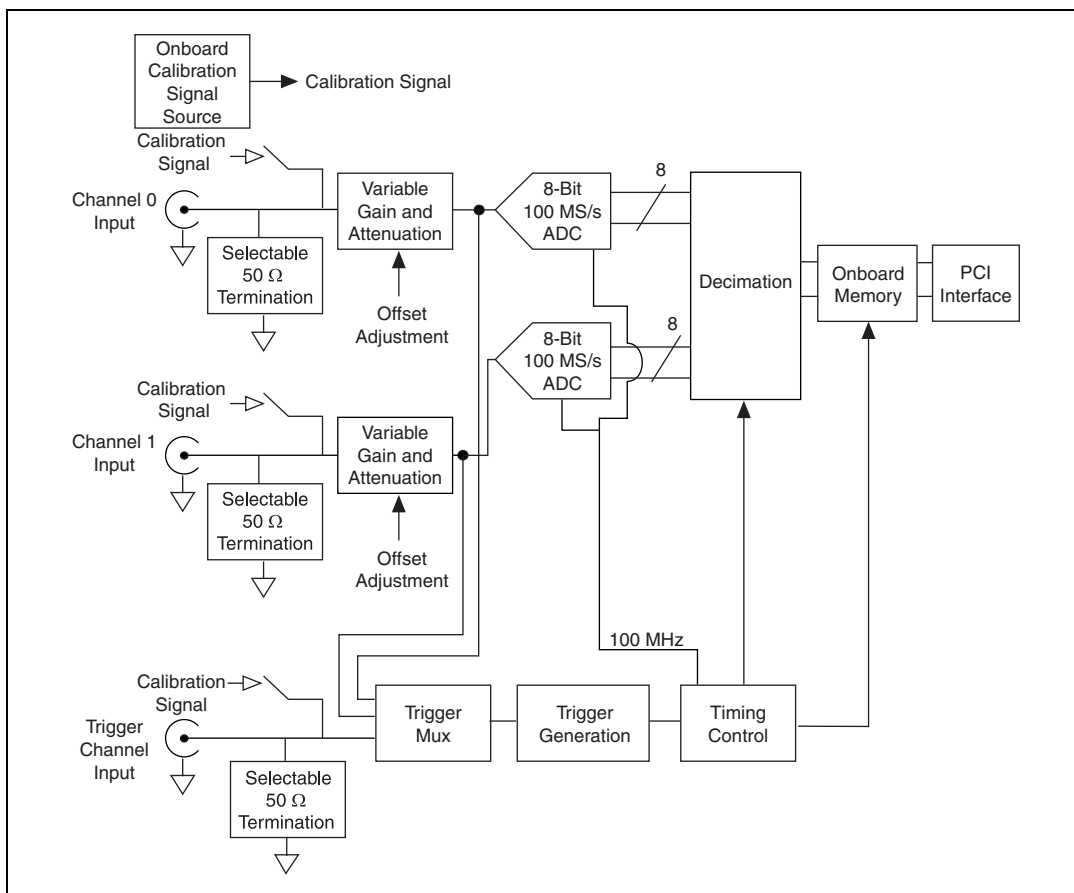

Figure 2-1. NI 5112 Block Diagram

Measurement Fundamentals

The NI 5112 has a programmable gain amplifier (PGA) at the analog input. The purpose of the PGA is to accurately interface to and scale the signal presented at the connector for the analog-to-digital converter (ADC) regardless of source impedance, source amplitude, or DC biasing.

Input Ranges

To optimize the ADC resolution, you can select different gains for the PGA. In this way, you can scale your input signal to match the full input range of the converter. The NI 5112 PGA offers a variable input range, from ± 0.025 V to ± 25 V.

These input ranges are available in 10% steps. For example, some typical ranges are 48.5 mV, 53.3 mV, 58.7 mV, 64.6 mV, 71.0 mV, 78.1 mV, 86.1 mV, and so on. Notice that each range is 10% higher than the one before it. The second value, 53.3, is found by adding 10% to the first value ($48.5 + 4.85$). Since the ranges are calibrated on a per device basis, the ranges of your device may be slightly different than the ones listed here. When you request a range, the driver software automatically coerces the requested range up to the first available range.

Input Impedance

The input impedance of the NI 5112 is software selectable between 50 Ω and 1 M Ω . The output impedance of the device connected to the NI 5112 and the input impedance of the NI 5112 form an impedance divider, which attenuates the input signal according to the following formula:

$$V_m = V_s \times \left(\frac{R_{in}}{R_{in} + R_s} \right)$$

where V_m is the measured voltage, V_s is the source voltage, R_s is the output impedance of the external device, and R_{in} is the input impedance.

If the device you are measuring has a very large output impedance, your measurements will be affected by this impedance divider. For example, if the device has 1 M Ω output impedance, and you have selected the 1 M Ω input impedance of the NI 5112, your measured signal will be half the actual signal value.

When performing measurements on systems that are expected to be terminated with a $50\ \Omega$ load, you can select the $50\ \Omega$ input impedance of the NI 5112. With $50\ \Omega$ input impedance selected, the input signal should be limited to $1\ V_{\text{rms}}$. Signals larger than this will not damage the NI 5112, but your measurements may be inaccurate. When the input reaches about $7\ V_{\text{rms}}$, an overload-protection relay will open, and the device will revert to $1\ M\Omega$ impedance.

AC Coupling

When you need to measure a small AC signal on top of a large DC component, you can use AC coupling. AC coupling rejects any DC component in your signal before it enters the PGA. Activating AC coupling inserts a capacitor in series with the input. You can select input coupling via software.

The boundary between DC and AC signals is called the *AC coupling cutoff frequency*. Frequencies above this cutoff pass through to the PGA, while frequencies below it are blocked. As shown in the following figure, adding an attenuator probe lowers this cutoff point.

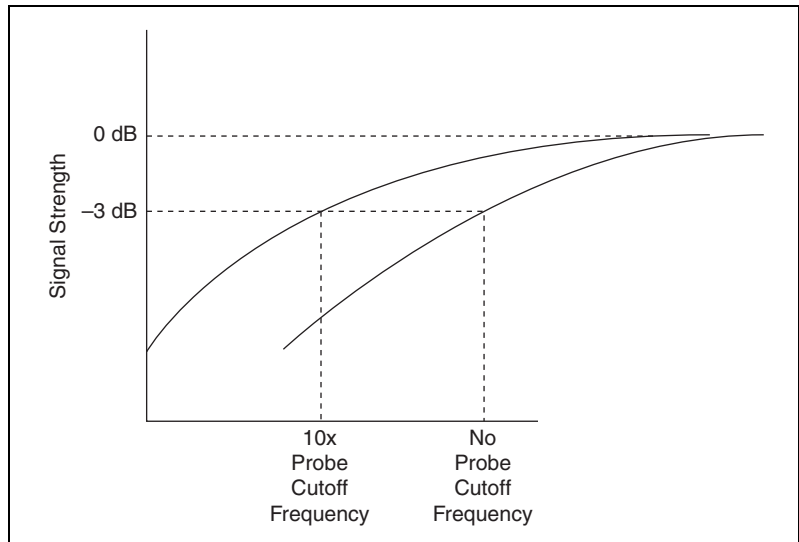

Figure 2-2. Impact of Cutoff Frequencies with Attenuator Probes

See Appendix B, *Digitizer Basics*, for more information on input coupling.

DC Offset

DC offset positions a waveform around an arbitrary DC value. Using DC offset allows you to examine small changes in the input signal, which can improve the accuracy of your measurement. For instance, imagine that you are acquiring the waveform shown in Figure 2-3 that outputs 0.75–1.25 V. Without using DC offset, you would need to specify a range of 2.5 V (± 1.25 V) to capture the waveform. Since the input range is adjustable in 10% steps, points would be acquired in 10 mV ($2.5 \text{ V}/256$) intervals. However, if you centered the waveform around 1 V with DC offset, you could limit the range to 0.5 V (± 0.25 V). This would reduce each step from 10 mV to 2 mV and improve the accuracy of the measurement. You can apply up to 50 V of DC offset to the NI 5112 input stage.

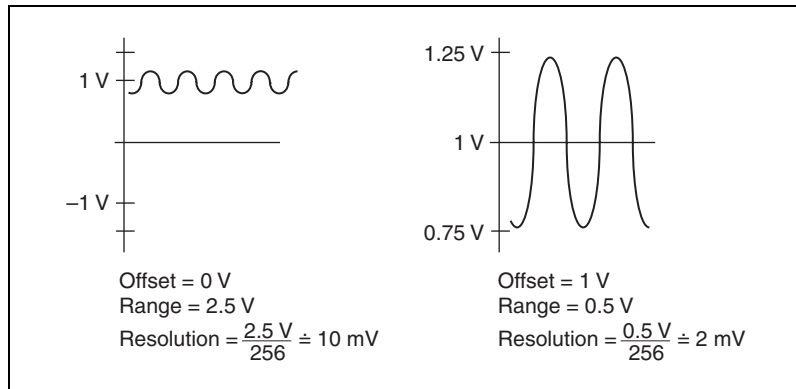

Figure 2-3. DC Offset

Table 2-1 lists the maximum DC offset for a given input voltage range.

Table 2-1. Maximum DC Offset

Vertical Range	Maximum Selectable Offset
50 mV–500 mV	$\pm 500 \text{ mV}$
500 mV–5 V	$\pm 5 \text{ V}$
5 V–50 V	$\pm 50 \text{ V}$

20 MHz Bandwidth Limit

The NI 5112 has a selectable 20 MHz bandwidth limit on the analog input channels. This limit enables a lowpass filter that can remove unwanted noise above 20 MHz from your measurement.

External Trigger

The NI 5112 external trigger is a front panel BNC input that allows you to connect an analog signal as a trigger without connecting the trigger to one of the input channels. This external trigger allows you to use the input channels and external trigger concurrently. The input range for the external trigger input is ± 10 V. You can select either AC or DC coupling.

Acquisition System

The NI 5112 acquisition system controls the way samples are acquired and stored. Two sampling methods are available: *real-time sampling* and *random interleaved sampling* (RIS). Using real-time sampling, you can acquire data at a rate of $100 \text{ MS}/n$, where n is a number from 1 to $100e+6$. RIS can be used on repetitive signals to effectively extend the sampling rate above $100 \text{ MS}/s$. In RIS mode, you can sample at rates of $100 \text{ MS}/s \times n$, where n is a number from 2 to 25.

During the acquisition, samples are stored in a circular buffer that is continually rewritten until a trigger is received. After the trigger is received, the NI 5112 continues to acquire posttrigger samples if you have specified a posttrigger sample count. The acquired samples are placed into onboard memory. The number of posttrigger or pretrigger samples is limited only by the amount of onboard memory.

Acquisition Modes

Regardless of the user-requested sample rate, the NI 5112 ADC is always running at $100 \text{ MS}/s$. The NI 5112 can acquire data in one of two modes: normal and peak-detect. Figure 2-4 shows these modes. In normal mode, the NI 5112 stores a stream of 8-bit samples into the onboard memory at the requested sample rate. If you request a rate less than $100 \text{ MS}/s$, the timing engine of the NI 5112 only stores 1 sample in a group of n samples, effectively reducing the sample rate to $100 \text{ MS}/n$.

The NI 5112 can operate in peak-detect mode when sampling at rates less than $25 \text{ MS}/s$. In peak-detect mode, the NI 5112 stores two samples in a group of n samples, the maximum and minimum. Peak-detect mode is useful for detecting high-frequency noise and anomalies on a signal sampled at a slower rate. The maximum sample rate for peak detect is $25 \text{ MS}/s$. For peak detect, the sample rate must also be a multiple of four that is divisible by 100 ($100/n$, where n is a multiple of four). That means accepted sample rates include $25 \text{ MS}/s$ ($100/4 = 25$), $12.5 \text{ MS}/s$ ($100/8 = 12.5$), and so on.

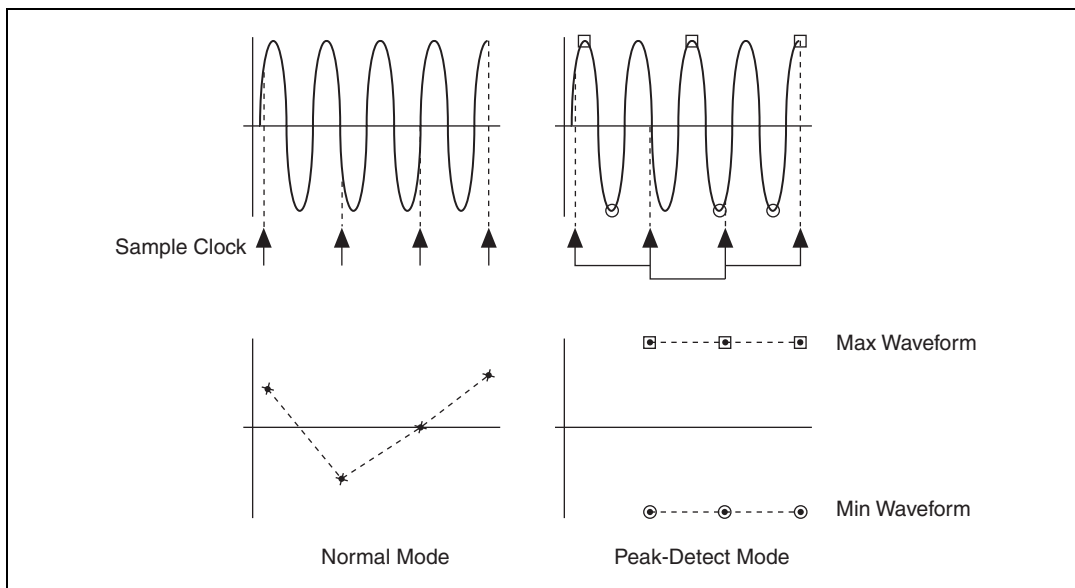

Figure 2-4. Normal Mode and Peak-Detect Mode

Calibration

The NI 5112 can calibrate numerous device parameters due to an advanced calibration scheme. There are two different calibration schemes depending on the type of calibration to be performed. *Internal calibration*, the more common of the two schemes, is performed via a software command that compensates for drifts caused by environmental temperature changes. Internal calibration can be executed without any external equipment connected. *External calibration*, which is performed much less frequently, is used to recalibrate the device when the specified calibration interval has expired. External calibration requires you to connect an external precision instrument to the device.

Internally Calibrating the NI 5112

There are a couple of simple ways to internally calibrate the NI 5112. You can use the VirtualBench-Scope front panel for calibration by selecting **Calibrate** from the **Utility** menu. You can also use the calibration example for your ADE to calibrate the device. See the [Programmatically Controlling Your NI 5112](#) section for information on where to find these examples.

When Internal Calibration Is Needed

To provide the maximum accuracy independent of temperature changes, the NI 5112 needs to be recalibrated when the environmental conditions change in your PC beyond a specified temperature range. Since the environment inside your system is most likely different from the environment under which the device was initially calibrated, you should recalibrate your device after installing it in your system. Be sure to first wait at least 15 minutes for your system to warm up to its operating temperature.

What Internal Calibration Does

By executing a software command, you can internally calibrate the NI 5112 without connecting any external equipment. Internal calibration uses a precision-traceable onboard reference for the calibration.

Internal calibration performs the following operations:

- Gain and offset are calibrated for each individual input range.
- AC flatness is calibrated over the entire bandwidth to be within specified tolerances.
- Analog trigger levels are calibrated.
- The time-to-digital converter used for RIS measurements is calibrated.

External Calibration

External calibration adjusts the internal reference on the NI 5112. Although the NI 5112 is factory calibrated, it needs periodic external calibration to verify that it is still within the specified accuracy. For more information on calibration, contact National Instruments or visit the National Instruments Web site at ni.com/calibration

Triggering and Arming

There are several triggering methods for the NI 5112. The trigger can be an analog level that is compared to the input or any of several digital inputs. You can also call a software function to trigger the device. Figure 2-5 shows the different trigger sources. The digital triggers are TTL-level signals with a minimum pulse-width requirement of 10 ns.

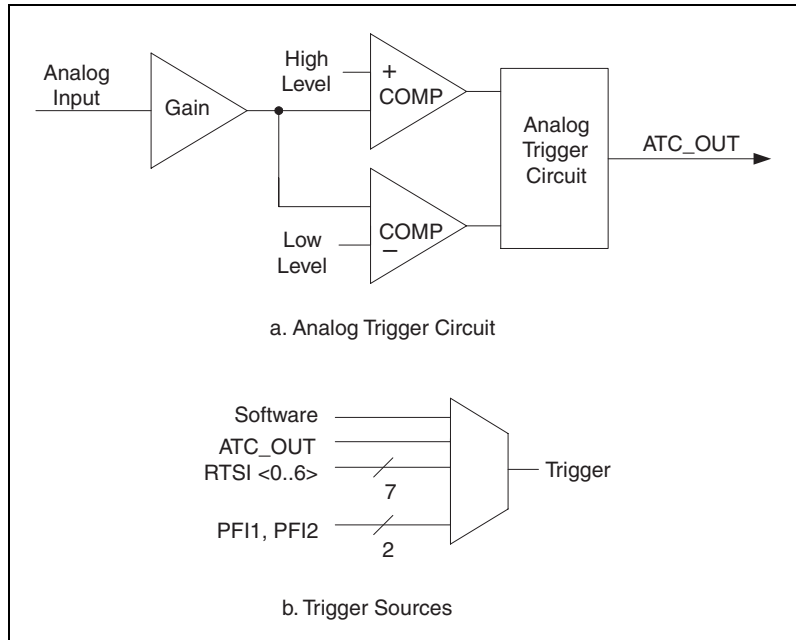

Figure 2-5. Trigger Sources

Analog Trigger Circuit

The analog trigger on the NI 5112 operates by comparing the current analog input to an onboard threshold voltage. This threshold voltage, the trigger value, can be set to any voltage within the current input range. A hysteresis value associated with the trigger is used to create a trigger window the signal must pass through before the trigger is accepted. Triggers can be generated on a rising-edge or falling-edge condition as illustrated in the following two figures.

High-Hysteresis Analog Triggering Mode

In high-hysteresis analog triggering mode, the trigger is generated when a signal crosses above the hysteresis value and then crosses above the trigger value. The signal must cross back below the hysteresis value before another trigger is generated.

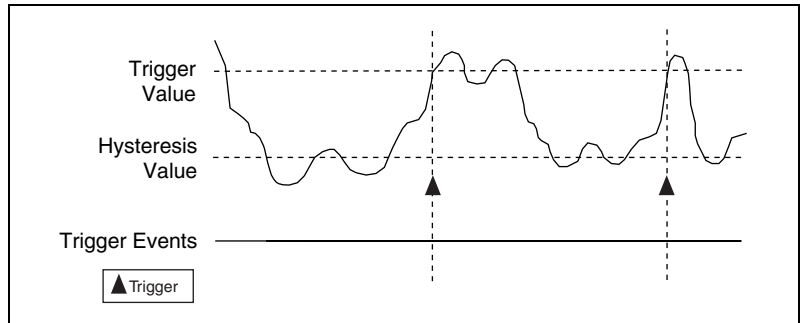

Figure 2-6. High-Hysteresis Analog Triggering Mode

Low-Hysteresis Analog Triggering Mode

In low-hysteresis analog triggering mode, the trigger is generated when the signal crosses below the hysteresis value and then crosses the trigger value. The signal must cross back above the hysteresis value before another trigger is generated.

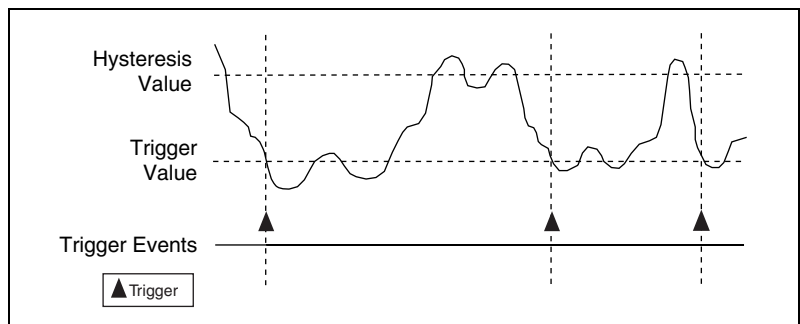

Figure 2-7. Low-Hysteresis Analog Triggering Mode

Rising-Edge Analog Trigger

Rising-edge analog trigger mode is the same as high-hysteresis analog trigger mode, except that the hysteresis value used is automatically set to 2.5% of the range of the chosen trigger source.

Falling-Edge Analog Trigger

Falling-edge analog trigger mode is the same as low-hysteresis analog trigger mode, except that the hysteresis value used is automatically set to 2.5% of the range of the chosen trigger source.

Trigger Hold-Off

The trigger hold-off is a length of time that the NI 5112 waits after a trigger is accepted before the next acquisition starts. In other words, when a trigger is received during an acquisition, the trigger counter is loaded with the desired hold-off time. Hardware is not rearmed until the counter has expired or the current acquisition completes, whichever is longer.

The time the acquisition takes to complete from the time a trigger occurs is determined by the following equation:

$$\text{acquisition completion time} = \frac{\text{posttrigger samples}}{\text{sample rate (MS/s)}}$$

If this time is larger than the trigger hold-off time, the trigger hold-off has no effect because triggers are always rejected during acquisition.

Trigger hold-off is provided in hardware using a 32-bit counter clocked by a 25 MHz internal timebase. With this configuration, you can select a hardware hold-off value of 100 μs to 171.79 s in increments of 40 ns.

Figure 2-8 shows a timing diagram of signals when hold-off is enabled and the hold-off time is longer than posttriggered acquisition.

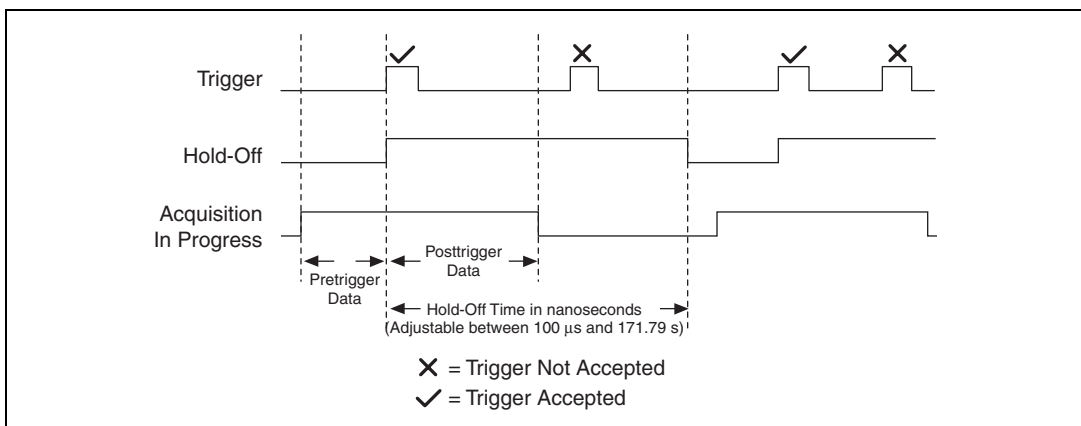

Figure 2-8. Timing with Hold-Off Enabled

Memory

The NI 5112 acquires samples into onboard memory before transferring them to the host computer. The minimum size for a buffer is approximately 256 8-bit samples, although you can specify smaller buffers in software. When specifying a smaller buffer size, the minimum number of points are still acquired into onboard memory, but only the specified number of points are transferred into the host computer's memory.

Multiple Record Acquisitions

You can configure the NI 5112 so that after a trigger has been received and the posttrigger samples have been stored, it automatically begins another acquisition that is stored in another memory record on the device. This process is a *multiple record acquisition*. To perform multiple record acquisitions, configure the NI 5112 for the number of records to be acquired, then start the acquisition. The NI 5112 acquires an additional record each time a trigger is accepted until all the requested records have been stored in memory. After the initial setup, this process does not require software intervention.

Between each record, there is a *dead time* of approximately 500 ns during which no triggers are accepted. During this time, the memory controller sets up for the next record. There is also a hold-off of 100 μ s from the last trigger in a record to the start of a new record. That means that the actual dead time will be the greater of the between-record dead time (500 ns + post-trigger storage time) and the 100 μ s hold-off time.

There may also be additional dead time while the minimum number of pretrigger samples are being acquired. To increase the dead time between records, use the trigger hold-off feature. Figure 2-9 shows a timing diagram of a multiple record acquisition.

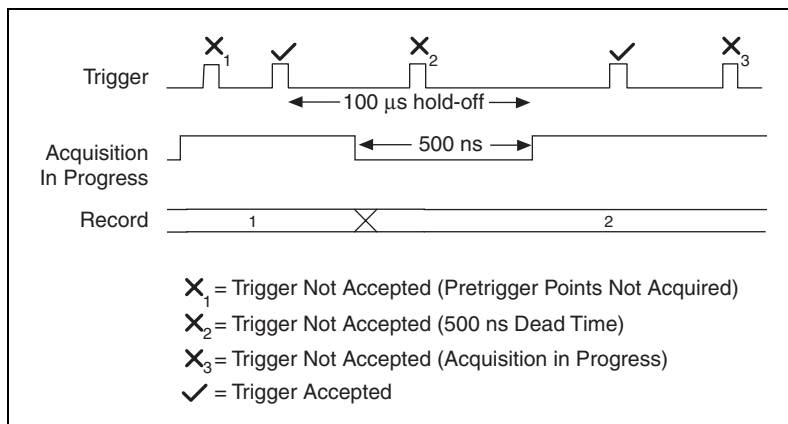

Figure 2-9. Multiple Record Acquisition

Synchronizing Multiple Devices

The NI 5112 uses a phase-locked loop to synchronize the 100 MHz sample clock to a 10 MHz reference clock. This reference frequency can be supplied by a crystal oscillator on the device or through an external frequency input. The NI 5112 can also output its 10 MHz reference clock to synchronize other NI 5112 devices or other equipment to the same reference clock.

Synchronizing Multiple PXI Devices

The PXI bus has the following timing and triggering features that can be used to synchronize multiple NI 5112s:

- **System Reference Clock**—This is a 10 MHz clock with 25 ppm accuracy. It is independently distributed to each PXI peripheral slot through equal-length traces with a skew of less than 1 ns between slots. Multiple devices can use this common timebase for synchronization. This allows each NI 5112 to phase lock to the system clock.
- **Trigger Bus**—This bus features eight bidirectional lines that link all PXI slots, providing interdevice synchronization and communication. The skew from slot to slot is less than 10 ns.
- **Star Trigger**—This special trigger slot provides an independent dedicated bidirectional line for each of up to 13 peripheral slots on a single backplane. All lines are matched in length, which provides a low slot-to-slot skew of less than 1 ns. A star trigger controller plugged into this slot can route triggers and clocks among peripheral slots.

To synchronize multiple NI 5112s, follow this procedure:

1. Distribute the PXI 10 MHz system reference clock to all devices.
2. Distribute a clock synchronization pulse signal from the master to slaves. This pulse synchronizes the clock dividers on each NI 5112.
3. Distribute the master trigger signal across the STAR bus lines to all devices.



Note To make use of the STAR bus triggering, the master has to reside in the STAR controller slot, which is slot 2 in the PXI chassis.

Synchronizing Multiple PCI Devices

To synchronize the NI 5112s for PCI clock dividers, you must connect the boards with a National Instruments Real Time System Integration (RTSI) bus cable. The RTSI bus is a dedicated high-speed digital bus designed to facilitate system integration by low-level, high-speed real-time communication between National Instruments devices. Using RTSI, National Instruments devices are able to share high-speed digital signals with no external cabling. For PCI devices, the physical bus interface is an internal 34-pin connector, and signals are shared via a ribbon cable inside the PC enclosure. The RTSI bus has seven bidirectional trigger lines and one bidirectional clock signal. RTSI cables are available for chaining two, three, four, or five devices together.

To synchronize multiple NI 5112s for PCI, follow this procedure:

1. Use the RTSI bus clock line to distribute the 10 MHz reference clock from the master to all slaves.
2. Distribute a clock synchronization pulse through one of the RTSI trigger lines from master to slaves. This pulse synchronizes the clock dividers on each NI 5112.
3. Distribute the master trigger signal through one of the designated RTSI trigger lines to all slaves.

PFI Lines and Synchronization

The NI 5112 has two front-panel digital lines that can accept a trigger, accept or generate a reference clock, or output a square wave of programmable frequency. With PFI lines, you can synchronize to third-party equipment that may not use the RTSI or the PXI timing and triggering buses. The function of each PFI line is independent; however, only one trigger source can be accepted during acquisition.

PFI Lines as Inputs

You can select PFI1 or PFI2 as an input for a trigger or a reference clock. For instance, you can accept a 10 MHz reference clock from an external source rather than using the PXI backplane 10 MHz system reference clock or the clock of another NI 5112 through the RTSI clock line.

PFI Lines as Outputs

You can select PFI1 or PFI2 to output several digital signals:

- Reference Clock is a 10 MHz TTL-level clock signal. You can use the reference clock to synchronize another NI 5112 configured as a slave device residing in another PCI or PXI chassis, or other equipment that can accept a 10 MHz reference clock.
- Frequency Output is a 1 kHz digital pulse-train signal with a 50% duty cycle, which means that the signal is high and low for the same length of time. Commonly, the Frequency Output signal provides a signal for compensating a passive probe.
- Trigger Output is a TTL signal that pulses to a high level for at least 40 ns after the board triggers.

Specifications

This appendix lists the specifications of the NI 5112. These specifications are typical at 25 °C unless otherwise specified.

Acquisition System

Resolution	8 bits
Bandwidth (–3 dB)	100 MHz maximum 20 MHz typical with bandwidth limit enabled
Number of channels	2 simultaneously sampled, single ended
Maximum sample rate.....	2.5 GS/s repetitive, 100 MS/s single-shot
Onboard sample memory	16 MB per channel
Calibrated vertical ranges.....	± 25 mV to ± 25 V in 10% steps
Calibrated offset ranges	± 500 mV for vertical ranges smaller than 500 mV, ± 5 V for vertical ranges between 500 mV and 5 V, ± 50 V for vertical ranges greater than 5 V
DC accuracy	± 2.5 % of range setting ± 0.5 % of offset setting
Input coupling	DC or AC, software selectable
AC coupling cutoff frequency (–3 dB)	11 Hz with 1 \times probe 1.1 Hz with 10 \times probe

Input impedance	1 M Ω 30 pF or 50 Ω software selectable. With 50 Ω input impedance, input signal should be below 1 V _{rms} to maintain measurement accuracy.
Input protection.....	\pm 42 V (DC + peak AC)

Timebase System

Number of timebases	10 MHz PXI, RTSI clock, and 10 MHz onboard reference
Clock accuracy (as master)	50 ppm
Clock input tolerance (as slave).....	1% minimum
Clock input levels	TTL
Sampling clock frequency	100 MHz fixed, data can be decimated by n where $1 < n < 100e6$
Synchronization between boards	Via PXI backplane 10 MHz reference clock or digital trigger input (NI 5112 for PXI); via RTSI clock line or digital trigger input (NI 5112 for PCI)

Triggering System

Modes	Edge, hysteresis, analog, digital
Source	Ch0, Ch1, TRIG, PFI<1..2>, RTSI <0..6>, PXI-Star
Slope	Rising/falling
Hysteresis.....	Fully programmable
Coupling	DC or AC on CH0, CH1, TRIG
Pretrigger depth	Up to 16 MB
Posttrigger depth.....	Up to 16 MB
Holdoff time	100 μ s to 171.79 s

Trigger sensitivity	>1000 steps in full-scale voltage range
DC accuracy (Ch 0, Ch 1).....	$\pm 2.5\%$ of range setting $\pm 0.5\%$ of offset setting
DC accuracy (TRIG).....	± 500 mV
Bandwidth	100 MHz
TRIG input range	± 10 V
TRIG input impedance.....	1 M Ω 30 pF or 50 Ω , software selectable
TRIG input protection.....	± 42 V (DC + peak AC)

Acquisition Methods

Random interleaved sampling (RIS).....	200 MS/s to 2.5 GS/s effective sample rate for repetitive signals only
Real-time sampling	1 S/s to 100 MS/s sample rate for transient and repetitive signals

Power Requirements

+3.3 VDC	0.5 A
+5 VDC	1.5 A
+12 VDC	80 mA
-12 VDC	120 mA

Physical

Dimensions.....	10 \times 16 cm (4.2 \times 6.87 in.)
-----------------	--

I/O Connectors

Analog inputs CH0, CH1	BNC female
Analog trigger TRIG	BNC female
Digital trigger PFI1	SMB female
Digital trigger PFI2	9-pin DIN

Operating Environment

Ambient temperature	0 to 40 °C
Relative humidity	10 to 90% noncondensing

Storage Environment

Ambient temperature	-20 to 70 °C
Relative humidity	5 to 95% noncondensing

Safety

Designed in accordance with IEC-61010-1, UL 3111-1, and CAN/CSA C22.2 no. 1010.1 for electrical measuring and test equipment

Approved for altitudes up to 2000 m

Installation Category II

Pollution Degree 2

Indoor use only

Certifications and Compliances

CE Mark Compliance

Calibration

Internal	Internal calibration is done on software command. The calibration involves gain, offset, frequency response, and timing adjustment for all input ranges.
Interval	24 hours, or any time temperature changes beyond ± 2 °C from temperature at which last internal calibration was performed
External	Internal reference requires external recalibration
Interval	5 years
Warm-up time	15 minutes

Digitizer Basics

This appendix explains basic information you need to understand about making measurements with digitizers, including important terminology.

Understanding Digitizers

To understand how digitizers work, you should be familiar with the Nyquist theorem and how it affects analog bandwidth and sample rate. You should also understand terms including vertical sensitivity, analog-to-digital converter (ADC) resolution, record length, and triggering options.

Nyquist Theorem

The Nyquist theorem states that a signal must be sampled at least twice as fast as the bandwidth of the signal to accurately reconstruct the waveform; otherwise, the high-frequency content will *alias* at a frequency inside the spectrum of interest (passband). An alias is a false lower frequency component that appears in sampled data acquired at too low a sampling rate. Figure B-1 shows a 5 MHz sine wave digitized by a 6 MS/s ADC. The dotted line indicates the aliased signal recorded by the ADC at that sample rate.

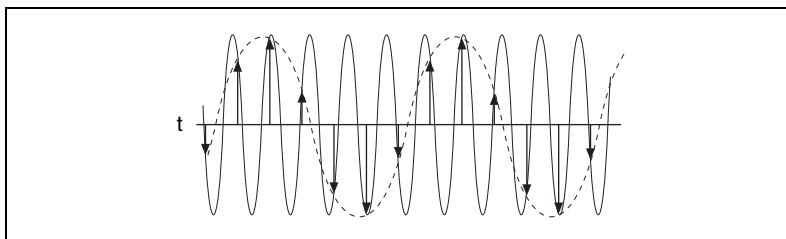

Figure B-1. Sine Wave Demonstrating the Nyquist Frequency

The 5 MHz frequency aliases back in the passband, falsely appearing as a 1 MHz sine wave. To prevent aliasing in the passband, a lowpass filter limits the frequency content of the input signal above the Nyquist rate.

Analog Bandwidth

Analog bandwidth describes the frequency range (in Hertz) in which a signal can be digitized accurately. This limitation is determined by the inherent frequency response of the input path, which causes loss of amplitude and phase information. Analog bandwidth is the frequency at which the measured amplitude is 3 dB below the actual amplitude of the signal. This amplitude loss occurs at very low frequencies if the signal is AC coupled and at very high frequencies regardless of coupling. When the signal is DC coupled, the bandwidth of the amplifier will extend all the way to the DC voltage. Figure B-2 illustrates the effect of analog bandwidth on a high-frequency signal. The result is a loss of high-frequency components and amplitude in the original signal as the signal passes through the instrument.

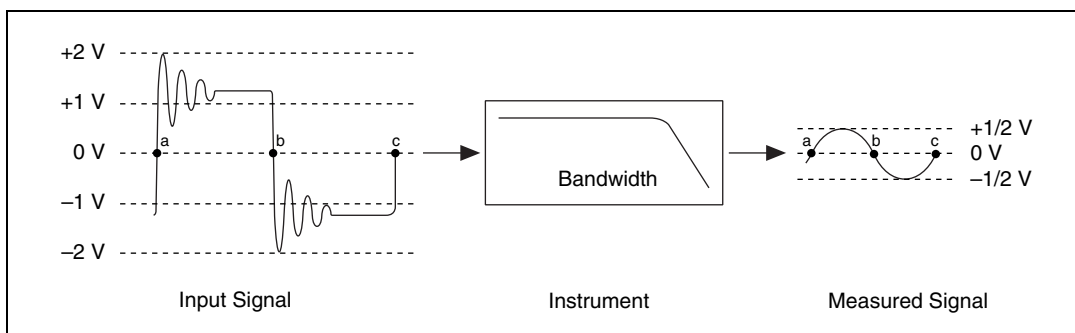

Figure B-2. Analog Bandwidth

Sample Rate

Sample rate is the rate at which a signal is sampled and digitized by an ADC. According to the Nyquist theorem, a higher sample rate produces accurate measurement of higher frequency signals if the analog bandwidth is wide enough to let the signal to pass through without attenuation. A higher sample rate also captures more waveform details. Figure B-3 illustrates a 1 MHz sine wave sampled by a 2 MS/s ADC and a 20 MS/s ADC. The faster ADC digitizes 20 points per cycle of the input signal compared with 2 points per cycle with the slower ADC. In this example, the higher sample rate more accurately captures the waveform shape as well as frequency.

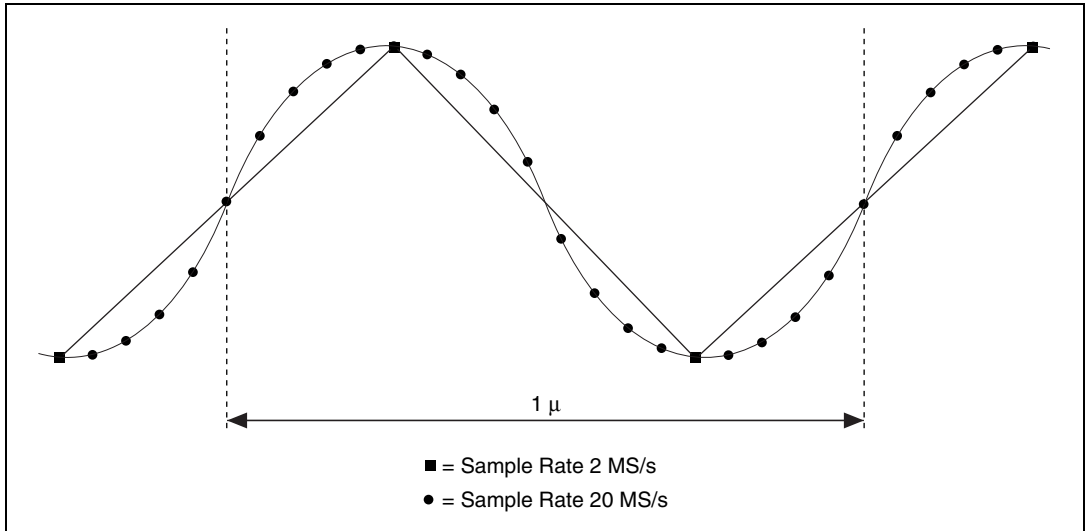

Figure B-3. 1 MHz Sine Wave Sample

Vertical Sensitivity

Vertical sensitivity describes the smallest input voltage change the digitizer can capture. This limitation is because one distinct digital voltage encompasses a range of analog voltages. Therefore, a minute change in voltage at the input might not be noticeable at the output of the ADC. This parameter depends on the input range, gain of the input amplifier, and ADC resolution; it is specified in volts per LSB. Figure B-4 shows the transfer function of a 3-bit ADC with a vertical range of 5 V having a vertical sensitivity of 5/8 V/LSB.

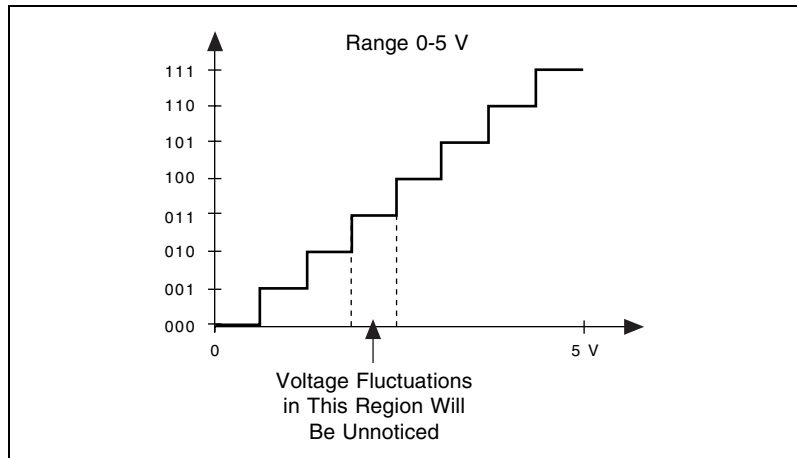

Figure B-4. Transfer Function of a 3-Bit ADC

ADC Resolution

ADC resolution limits the accuracy of a measurement. The higher the resolution (number of bits), the more accurate the measurement. An 8-bit ADC divides the vertical range of the input amplifier into 256 discrete levels. With a vertical range of 10 V, the 8-bit ADC cannot resolve voltage differences smaller than 39 mV. In comparison, a 12-bit ADC with 4,096 discrete levels can resolve voltage differences as small as 2.4 mV.

Record Length

Record length refers to the amount of memory dedicated to storing digitized samples for postprocessing or display. In a digitizer, record length limits the maximum duration of a single-shot acquisition. For example, with a 1,000-sample buffer and a sample rate of 20 MHz, the duration of acquisition is 50 μ s (the number of points multiplied by the acquisition time/point or $1,000 \times 50$ ns). With a 100,000-sample buffer and a sample rate of 20 MHz, the duration of acquisition is 5 ms ($100,000 \times 50$ ns).

Triggering Options

One of the biggest challenges of making a measurement is to successfully trigger the signal acquisition at the point of interest. Since most high-speed digitizers actually record the signal for a fraction of the total time, they can easily miss a signal anomaly if the trigger point is set incorrectly. The NI 5112 is equipped with sophisticated triggering options such as trigger thresholds, programmable hysteresis values, and trigger hold-off. The NI 5112 also has two digital triggers that give you more flexibility in triggering by allowing you to connect a TTL/CMOS digital signal to trigger the acquisition.

Random Interleaved Sampling

Random Interleaved Sampling (RIS) is a form of Equivalent Time Sampling (ETS) that allows acquisition of pretriggered data. ETS refers to any method used to sample signals in such a way that the apparent sampling rate is higher than the real sampling rate. ETS is accomplished by sampling different points along the waveform for each occurrence of the trigger, and then reconstructing the waveform from the data acquired over many cycles.

In RIS, the arrival of the waveform trigger point occurs at some time randomly distributed between two sampling instants. The time from the trigger to the next sampling instant is measured, and this measurement allows the waveform to be reconstructed. Figure B-5 shows three occurrences of a waveform. In Frame 1, the dotted points are sampled, and the trigger occurs time t_1 before the next sample. In Frame 2, the square points are sampled, and the trigger occurs time t_2 before the next sample. In Frame 3, the triangular points are sampled, and the trigger occurs time t_3 before the next sample. With knowledge of the three times, t_1 , t_2 , and t_3 , you can reconstruct the waveform as if it had been sampled at a higher rate, as shown at the bottom of the figure.

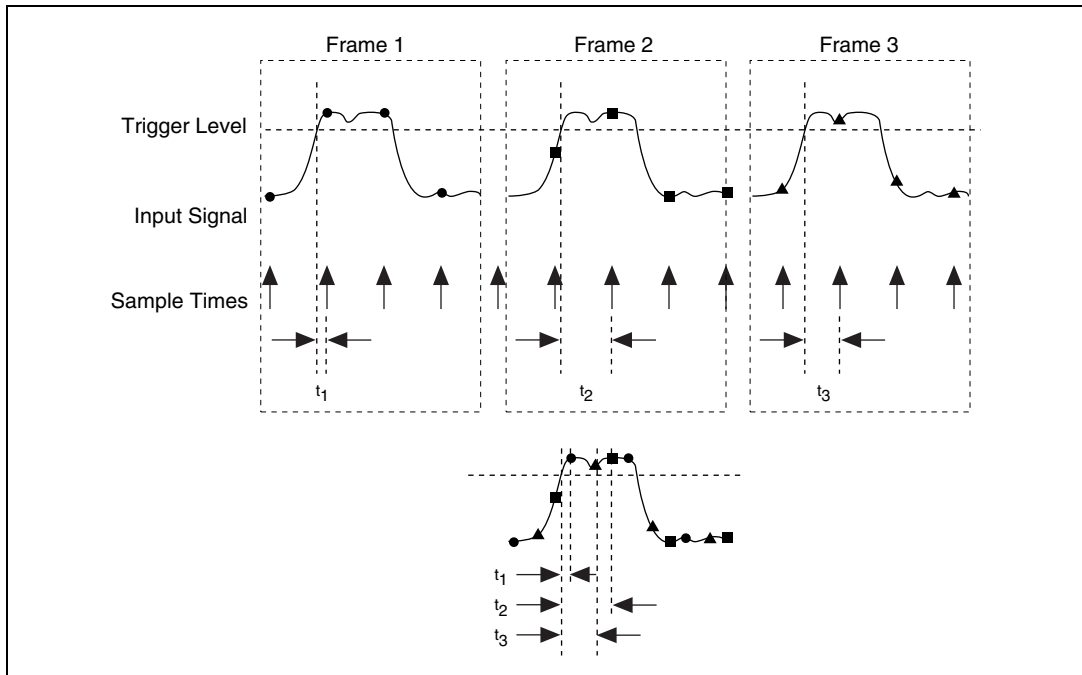

Figure B-5. Waveform Reconstruction with RIS

The time measurement is made with a time-to-digital converter (TDC). The resolution of the TDC is the number of physical bins to which the TDC can quantize the trigger arrival time. This resolution should be several times higher than the maximum desired interpolation factor, which is the maximum number of logical bins to which you want the trigger arrival time quantized. The higher resolution ensures that when the TDC output is requantized to the desired interpolation factor, all output values have a roughly equal probability of occurrence; that is, all logical bins will contain approximately the same number of physical bins.

For example, consider the maximum interpolation factor to be 5. If the TDC could output values from 0 to 15, then each logical bin will contain three physical bins, as shown in Figure B-6.

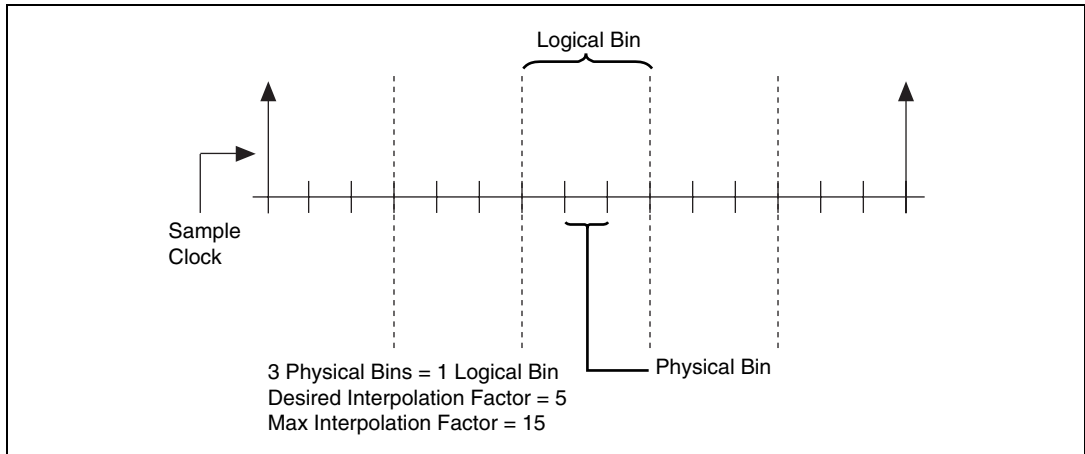

Figure B-6. Relationship between Interpolation Factor, Logical Bins, and Physical Bins

The maximum interpolation factor on the NI 5112 is 25, resulting in a maximum ETS rate of 2.5 GS/s. At this rate, the ratio of logical bins to physical bins is approximately 1:40.

Making Accurate Measurements

For accurate measurements, you should use the right settings when acquiring data with your NI 5112. Knowing the characteristics of the signal in consideration helps you to choose the correct settings. Such characteristics include:

- **Peak-to-peak value**—This parameter, in units of volts, reflects the maximum change in signal voltage. If V is the signal voltage at any given time, then $V_{\text{pk-to-pk}} = V_{\text{max}} - V_{\text{min}}$. The peak-to-peak value affects the vertical sensitivity or gain of the input amplifier. If you do not know the peak-to-peak value, start with the largest input range, and decrease it until the waveform is digitized using the maximum dynamic range without clipping the signal. Refer to Appendix A, [Specifications](#), for the maximum input range for your NI 5112. Figure B-7 shows how different ranges affect the resolution of the signal you acquire.

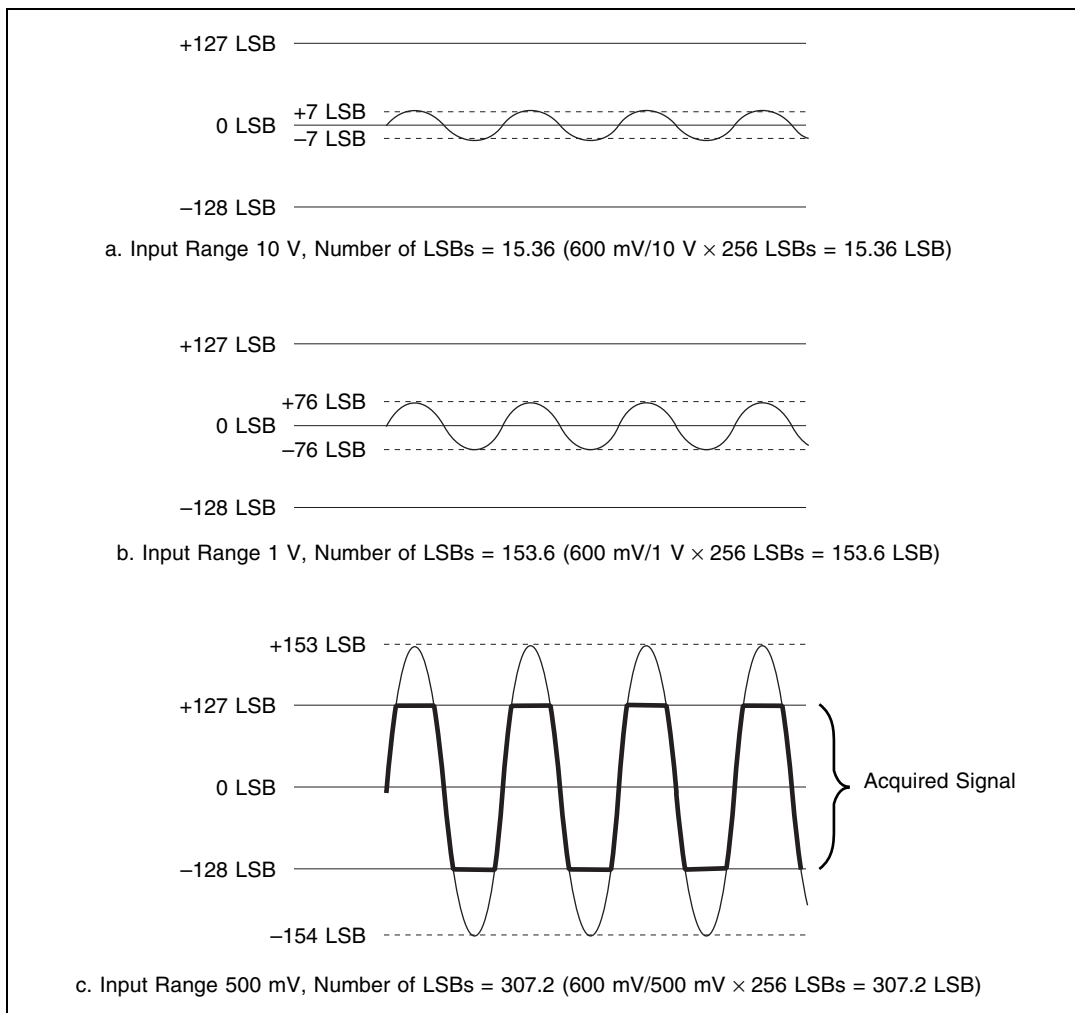

Figure B-7. Dynamic Range of an 8-Bit ADC with Three Different Gain Settings and a 600 mV Peak-to-Peak Input Signal

- Source impedance—Most digitizers and digital storage oscilloscopes (DSOs) have a $1 \text{ M}\Omega$ input resistance in the passband. If the source impedance is large, the signal will be attenuated at the amplifier input and the measurement will be inaccurate. If the source impedance is unknown but suspected to be high, change the attenuation ratio on your probe and acquire data. In addition to the input resistance, all digitizers, DSOs, and probes present some input capacitance in parallel with the resistance. This capacitance can interfere with your measurement in much the same way as the resistance does.

- Input frequency—If your sample rate is less than twice the highest frequency component at the input, the frequency components above half your sample rate will alias in the passband at lower frequencies, indistinguishable from other frequencies in the passband. If the signal's highest frequency is unknown, you should start with the digitizer's maximum sample rate to prevent aliasing and reduce the digitizer's sample rate until the display shows either enough cycles of the waveform or the information you need.
- General signal shape—Some signals are easy to capture by ordinary triggering methods. A few iterations on the trigger level finally render a steady display. This method works for sinusoidal, triangular, square, and saw tooth waves. Some of the more elusive waveforms, such as irregular pulse trains, runt pulses, and transients, may be more difficult to capture. Figure B-8 shows an example of a difficult pulse-train trigger.

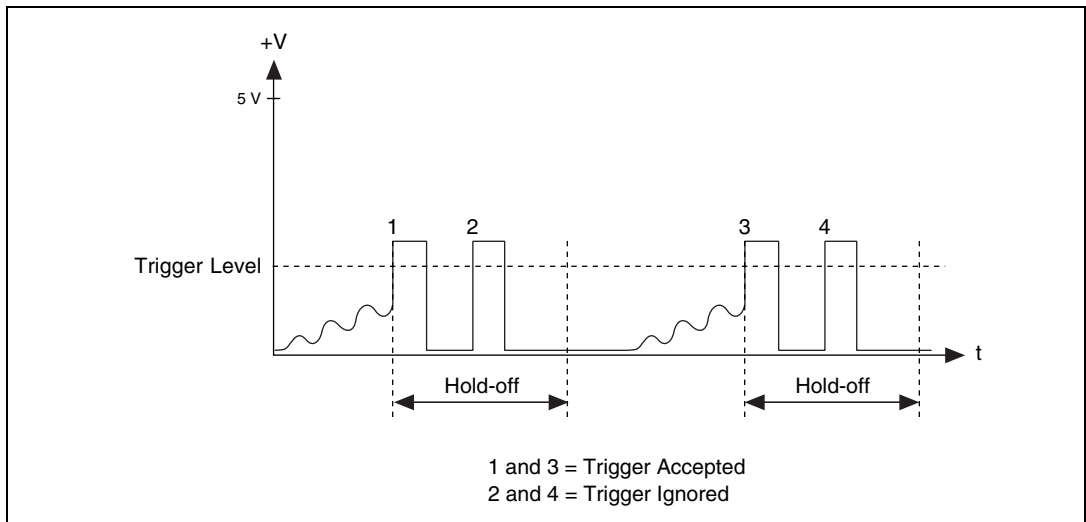

Figure B-8. Difficult Pulse Train Signal

Ideally, the trigger event should occur at condition one, but sometimes the instrument may trigger on condition two because the signal crosses the trigger level. You can solve this problem without using complicated signal processing techniques by using *trigger hold-off*, which lets you specify a time from the trigger event to ignore additional triggers that fall within that time. With an appropriate hold-off value, the waveform in Figure B-8 can be properly captured by discarding conditions two and four.

- Input coupling—You can configure the input channels on your NI 5112 to be DC coupled or AC coupled. DC coupling allows DC and low-frequency components of a signal to pass through without attenuation. In contrast, AC coupling removes DC offsets and attenuates low frequency components of a signal. This feature can be exploited to zoom in on AC signals with large DC offsets, such as switching noise on a 12 V power supply. Refer to Appendix A, [Specifications](#), for input limits that must be observed regardless of coupling.



Technical Support Resources

Web Support

National Instruments Web support is your first stop for help in solving installation, configuration, and application problems and questions. Online problem-solving and diagnostic resources include frequently asked questions, knowledge bases, product-specific troubleshooting wizards, manuals, drivers, software updates, and more. Web support is available through the Technical Support section of ni.com

NI Developer Zone

The NI Developer Zone at ni.com/zone is the essential resource for building measurement and automation systems. At the NI Developer Zone, you can easily access the latest example programs, system configurators, tutorials, technical news, as well as a community of developers ready to share their own techniques.

Customer Education

National Instruments provides a number of alternatives to satisfy your training needs, from self-paced tutorials, videos, and interactive CDs to instructor-led hands-on courses at locations around the world. Visit the Customer Education section of ni.com for online course schedules, syllabi, training centers, and class registration.

System Integration

If you have time constraints, limited in-house technical resources, or other dilemmas, you may prefer to employ consulting or system integration services. You can rely on the expertise available through our worldwide network of Alliance Program members. To find out more about our Alliance system integration solutions, visit the System Integration section of ni.com

Worldwide Support

National Instruments has offices located around the world to help address your support needs. You can access our branch office Web sites from the Worldwide Offices section of ni.com. Branch office Web sites provide up-to-date contact information, support phone numbers, e-mail addresses, and current events.

If you have searched the technical support resources on our Web site and still cannot find the answers you need, contact your local office or National Instruments corporate. Phone numbers for our worldwide offices are listed at the front of this manual.

Glossary

Prefix	Meanings	Value
p-	pico-	10^{-12}
n-	nano-	10^{-9}
μ -	micro-	10^{-6}
m-	milli-	10^{-3}
k-	kilo-	10^3
M-	mega-	10^6
G-	giga-	10^9

Numbers/Symbols

%	percent
+	positive of, or plus
-	negative of, or minus
/	per
°	degree
±	plus or minus
Ω	ohm

A

A	amperes
AC	alternating current
AC coupled	the passing of a signal through a filter network that removes the DC component of the signal

A/D	analog-to-digital
ADC	analog-to-digital converter—an electronic device, often an integrated circuit, that converts an analog voltage to a digital number
ADC resolution	the resolution of the ADC, which is measured in bits. An ADC with 16 bits has a higher resolution, and thus a higher degree of accuracy, than a 12-bit ADC.
alias	a false lower frequency component that appears in sampled data acquired at too low a sampling rate
amplification	a type of signal conditioning that improves accuracy in the resulting digitized signal and reduces noise
amplitude flatness	a measure of how close to constant the gain of a circuit remains over a range of frequencies
attenuate	to reduce in magnitude
B	
b	bit—one binary digit, either 0 or 1
B	byte—eight related bits of data, an eight-bit binary number. Also used to denote the amount of memory required to store one byte of data.
bandwidth	the range of frequencies present in a signal, or the range of frequencies to which a measuring device can respond
buffer	temporary storage for acquired or generated data (software)
bus	the group of conductors that interconnect individual circuitry in a computer. Typically, a bus is the expansion vehicle to which I/O or other devices are connected. Examples of PC buses are the PCI and ISA bus.
C	
C	Celsius
clock	hardware component that controls timing for reading from or writing to groups

CMRR common-mode rejection ratio—a measure of an instrument’s ability to reject interference from a common-mode signal, usually expressed in decibels (dB)

counter/timer a circuit that counts external pulses or clock pulses (timing)

coupling the manner in which a signal is connected from one location to another

D

dB decibel—the unit for expressing a logarithmic measure of the ratio of two signal levels: $\text{dB} = 20\log_{10} V_1/V_2$, for signals in volts

DC direct current

default setting a default parameter value recorded in the driver. In many cases, the default input of a control is a certain value (often 0) that means *use the current default setting*.

device a plug-in data acquisition board, card, or pad. The NI 5112 is an example of a device.

differential input an analog input consisting of two terminals, both of which are isolated from computer ground, whose difference is measured

double insulated a device that contains the necessary insulating structures to provide electric shock protection without the requirement of a safety ground connection

drivers software that controls a specific hardware instrument

E

EEPROM electrically erasable programmable read-only memory—ROM that can be erased with an electrical signal and reprogrammed

equivalent time sampling any method used to sample signals in such a way that the apparent sampling rate is higher than the real sampling rate

event the condition or state of an analog or digital signal

F

filtering a type of signal conditioning that allows you to remove unwanted signals from the signal you are trying to measure

G

gain the factor by which a signal is amplified, sometimes expressed in decibels

H

hardware the physical components of a computer system, such as the circuit boards, plug-in boards, chassis, enclosures, peripherals, cables, and so on

harmonics multiples of the fundamental frequency of a signal

Hz hertz—per second, as in cycles per second or samples per second

I

in. inches

input bias current the current that flows into the inputs of a circuit

input impedance the measured resistance and capacitance between the input terminals of a circuit

instrument driver a set of high-level software functions that controls a specific plug-in DAQ board. Instrument drivers are available in several forms, ranging from a function callable language to a virtual instrument (VI) in LabVIEW.

interrupt a computer signal indicating that the CPU should suspend its current task to service a designated activity

interrupt level the relative priority at which a device can interrupt

I/O input/output—the transfer of data to/from a computer system involving communications channels, operator interface devices, and/or data acquisition and control interfaces

ISA industry standard architecture

K

- k kilo—the standard metric prefix for 1,000, or 10^3 , used with units of measure such as volts, hertz, and meters
- kS 1,000 samples

L

- LabVIEW laboratory virtual instrument engineering workbench—a graphical programming ADE developed by National Instruments
- LSB least significant bit

M

- m meters
- MB megabytes of memory
- memory buffer *See* [buffer](#)
- MS million samples
- MSB most significant bit

N

- noise an undesirable electrical signal—noise comes from external sources such as the AC power line, motors, generators, transformers, fluorescent lights, soldering irons, CRT displays, computers, electrical storms, welders, radio transmitters, and internal sources such as semiconductors, resistors, and capacitors. Noise corrupts signals you are trying to send or receive.
- Nyquist frequency a frequency that is one-half the sampling rate. *See* [Nyquist Sampling Theorem](#)
- Nyquist Sampling Theorem the theorem states that if a continuous bandwidth-limited analog signal contains no frequency components higher than half the frequency at which it is sampled, then the original signal can be recovered without distortion.

O

Ohm's Law	($R=V/I$)—the relationship of voltage to current in a resistance
overrange	a segment of the input range of an instrument outside of the normal measuring range. Measurements can still be made, usually with a degradation in specifications.
oversampling	sampling at a rate greater than the Nyquist frequency

P

passband	the frequency range that a filter passes without attenuation
PCI	Peripheral Component Interconnect—a high-performance expansion bus architecture originally developed by Intel to replace ISA and EISA; it is achieving widespread acceptance as a standard for PCs and workstations and offers a theoretical maximum transfer rate of 132 Mbytes/s
peak value	the absolute maximum or minimum amplitude of a signal (AC + DC)
PFI	Programmable Function Input
posttriggering	the technique to acquire a programmed number of samples after trigger conditions are met
pretriggering	the technique used on a device to keep a buffer filled with data, so that when the trigger conditions are met, the sample includes the data leading up to the trigger condition
PXI	PCI eXtensions for Instrumentation. PXI is an open specification that builds off the CompactPCI specification by adding instrumentation-specific features.

R

R	resistor
RAM	random-access memory
real-time sampling	sampling that occurs immediately

random interleaved sampling	method of increasing sample rate by repetitively sampling a repeated waveform
resolution	the smallest signal increment that can be detected by a measurement system. Resolution can be expressed in bits or in digits. The number of bits in a system is roughly equal to 3.3 times the number of digits.
rms	root mean square—a measure of signal amplitude; the square root of the average value of the square of the instantaneous signal amplitude
ROM	read-only memory
RTSI bus	real-time system integration bus—the National Instruments timing bus that connects devices directly, by means of connectors on top of the boards, for precise synchronization of functions

S

s	seconds
S	samples
sense	in four-wire resistance the sense measures the voltage across the resistor being excited by the excitation current
settling time	the amount of time required for a voltage to reach its final value within specified limits
S/s	samples per second—used to express the rate at which an instrument samples an analog signal
system noise	a measure of the amount of noise seen by an analog circuit or an ADC when the analog inputs are grounded

T

temperature coefficient	the percentage that a measurement will vary according to temperature. <i>See also</i> thermal drift .
thermal drift	measurements that change as the temperature varies

thermal EMFs	thermal electromotive forces—voltages generated at the junctions of dissimilar metals that are functions of temperature. Also called thermoelectric potentials.
thermoelectric potentials	See thermal EMFs
transfer rate	the rate, measured in bytes/s, at which data is moved from source to destination after software initialization and set up operations; the maximum rate at which the hardware can operate

U

undersampling	sampling at a rate lower than the Nyquist frequency—can cause aliasing
update rate	the number of output updates per second

V

V	volts
VAC	volts alternating current
VDC	volts direct current
V_{error}	voltage error
VI	virtual instrument—(1) a combination of hardware and/or software elements, typically used with a PC, that has the functionality of a classic stand-alone instrument (2) a LabVIEW software module (VI), which consists of a front panel user interface and a block diagram program
V_{rms}	volts, root mean square value

W

waveform shape	the shape the magnitude of a signal creates over time
working voltage	the highest voltage that should be applied to a product in normal use, normally well under the breakdown voltage for safety margin

Index

Numbers

20 MHz bandwidth limit, 2-4

A

AC coupling, 2-3

acquiring data, 1-3 to 1-7

 interactive control of NI 5112, 1-3

 multiple-record acquisitions, 2-11 to 2-12

 programmatic control of NI 5112, 1-3

 steps for, 1-4 to 1-5

 using VirtualBench-Scope soft front panel,
 1-6 to 1-7

acquisition modes

 normal mode and peak-detect mode
 (figure), 2-6

 overview, 2-5

 specifications, A-3

acquisition system

 normal and peak-detect, 2-5 to 2-6

 overview, 2-5

 sampling methods, 2-5

 specifications, A-1 to A-2

ADC resolution, B-4

analog bandwidth, B-2

analog trigger circuit, 2-8 to 2-10

 falling-edge analog trigger, 2-10

 high-hysteresis analog triggering mode, 2-9

 low-hysteresis analog triggering mode, 2-9

 rising-edge analog trigger, 2-9

arming. *See* triggering and arming.

B

bandwidth

 20 MHz bandwidth limit, 2-4

 analog bandwidth, B-2

block diagram of NI 5112, 2-1

BNC connectors, 1-1 to 1-2

C

calibration, 2-6 to 2-7

 external, 2-7

 internal, 2-6 to 2-7

 specifications, A-5

certifications and compliances, A-4

connectors

 BNC connectors, 1-1 to 1-2

 DIN connector, 1-1 to 1-2

 SMB connector, 1-1

 specifications, A-4

conventions used in manual, *vi*

customer education, C-1

D

data acquisition. *See* acquiring data.

DC offset, 2-4

dead time, in multiple record acquisitions, 2-11

digitizers, B-1 to B-10

 accurate measurements, B-7 to B-10

 input coupling, B-10

 source impedance, B-8

 ADC resolution, B-4

 analog bandwidth, B-2

 Nyquist theorem, B-1

 random interleaved sampling, B-5 to B-7

 record length, B-4

 sample rate, B-2 to B-3

 settings for accurate measurements

 general signal shape, B-9

 input frequency, B-9

 peak-to-peak value, B-7 to B-8

- triggering options, B-5
- vertical sensitivity, B-3 to B-4

DIN connector, 1-1 to 1-2

E

Equivalent Time Sampling (ETS), B-5

external calibration, 2-7

external trigger, 2-5

F

falling-edge analog trigger, 2-10

H

hardware installation, 1-1

hardware overview, 2-1 to 2-14

- acquisition system, 2-5 to 2-6
- block diagram, 2-1
- calibration, 2-6 to 2-7
 - external, 2-7
 - internal, 2-6 to 2-7
- measurement fundamentals, 2-2 to 2-5
 - 20 MHz bandwidth limit, 2-4
 - AC coupling, 2-3
 - DC offset, 2-4
 - external trigger, 2-5
 - input impedance, 2-2 to 2-3
 - input ranges, 2-2
- memory, 2-11
- multiple-record acquisitions, 2-11 to 2-12
- synchronizing multiple devices, 2-12 to 2-14
 - PCI devices, 2-13
 - PFI lines and synchronization, 2-13 to 2-14
 - PXI devices, 2-12 to 2-13
- triggering and arming, 2-8 to 2-10
 - analog trigger circuit, 2-8 to 2-10
 - trigger hold-off, 2-10

high-hysteresis analog triggering mode, 2-9

I

impedance

- input, 2-2 to 2-3
- source, B-8

input coupling, B-10

input frequency, B-9

input impedance, 2-2 to 2-3

input ranges, 2-2

installing software and hardware, 1-1

interactive control of NI 5112, 1-3

internal calibration, 2-6 to 2-7

I/O connectors. *See* connectors.

L

low-hysteresis analog triggering mode, 2-9

M

measurement accuracy for digitizers, B-7 to B-10

- general signal shape, B-9
- input coupling, B-10
- input frequency, B-9
- peak-to-peak value, B-7 to B-8
- source impedance, B-8

measurement fundamentals, 2-2 to 2-5

- 20 MHz bandwidth limit, 2-4
- AC coupling, 2-3
- DC offset, 2-4
- external trigger, 2-5
- input impedance, 2-2 to 2-3
- input ranges, 2-2
- PGA (programmable gain amplifier), 2-2

memory, 2-11

multiple-record acquisitions, 2-11 to 2-12

N

NI 5112. *See also* hardware overview.

- acquiring data
 - interactive control of NI 5112, 1-3
 - programmatic control of NI 5112, 1-3
 - using VirtualBench-Scope soft front panel, 1-4 to 1-5
- block diagram, 2-1
- connectors, 1-1 to 1-2
 - safety information, 1-7 to 1-8
- NI Developer Zone, C-1
- NI-SCOPE software, 1-1
- normal acquisition mode, 2-5 to 2-6
- Nyquist theorem, B-1

O

operating environment specifications, A-4

P

PCI devices, synchronizing, 2-13

peak-detect acquisition mode, 2-5 to 2-6

peak-to-peak value for digitizers

- dynamic range of 8-bit ADC (figure), B-8
- overview, B-7

PFI lines, 2-13 to 2-14

- inputs, 2-14
- outputs, 2-14

PGA (programmable gain amplifier), 2-2

physical specifications, A-3

power requirement specifications, A-3

programmable gain amplifier (PGA), 2-2

programmatic control of NI 5112, 1-3

pulse train signal, difficult (figure), B-9

PXI devices, synchronizing, 2-12 to 2-13

R

random interleaved sampling (RIS)

- interpolation factor (figure), B-7
- overview, 2-5
- purpose and use, B-5 to B-7
- time measurement with time-to-digital converter, B-6 to B-7
- waveform reconstruction (figure), B-6

real-time sampling, 2-5

record length, for digitized samples, B-4

RIS. *See* random interleaved sampling (RIS).

rising-edge analog trigger, 2-9

S

safety

- hazardous voltages and hazardous operating conditions, 1-7 to 1-8
- specifications, A-4

sample rate, B-2 to B-3

sampling methods

- random interleaved (RIS), 2-5
- real-time, 2-5

signal shape, general, B-9

SMB connector, 1-1

soft front panel. *See* VirtualBench-Scope soft front panel.

software installation, 1-1

source impedance, B-8

specifications

- acquisition modes, A-3
- acquisition system, A-1 to A-2
- calibration, A-5
- certifications and compliances, A-4
- I/O connectors, A-4
- operating environment, A-4
- physical, A-3
- power requirements, A-3
- storage environment, A-4

- timebase system, A-2
- triggering system, A-2 to A-3
- Star Trigger, PXI devices, 2-12
- storage environment specifications, A-4
- synchronizing multiple devices, 2-12 to 2-14
 - PCI devices, 2-13
 - PFI lines and synchronization, 2-13 to 2-14
 - PXI devices, 2-12 to 2-13
 - specifications for timebase system, A-2
- system integration, by National Instruments, C-1
- System Reference Clock, PXI devices, 2-12

T

- TCD (time-to-digital converter), B-6
- technical support resources, C-1 to C-2
- timebase system specifications, A-2
- time-to-digital converter (TDC), B-6
- trigger, external, 2-5
- Trigger Bus, PXI devices, 2-12
- triggering and arming, 2-8 to 2-10
 - analog trigger circuit, 2-8 to 2-10
 - falling-edge analog trigger, 2-10
 - high-hysteresis analog triggering mode, 2-9
 - low-hysteresis analog triggering mode, 2-9
 - rising-edge analog trigger, 2-9
 - digitizer options, B-5
 - specifications, A-2 to A-3
 - trigger hold-off, 2-10, B-9
 - trigger sources (figure), 2-8

V

- vertical sensitivity, B-3 to B-4
- VirtualBench-Scope soft front panel
 - acquiring data, 1-4 to 1-5
 - features, 1-6 to 1-7

W

- Web support from National Instruments, C-1
- Worldwide technical support, C-2